

# Fiber-Fiber™ Optical Switch

## Quad (4) 2x2 Bypass

(SM, MM, Broadband, Bidirectional)



DATASHEET

BUY NOW

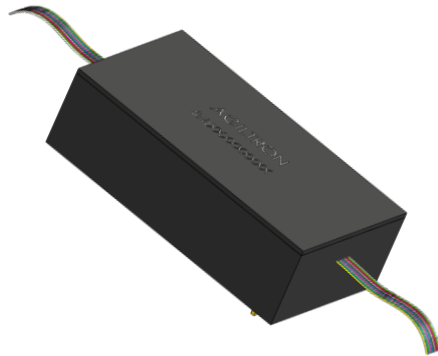

### Features

- Broadband
- High speed
- Ultra-high reliability
- Low insertion loss
- Compact

### Applications

- Network Bypass
- Network Protection
- Reconfigurable Optics
- Instrumentations

This series fiber optical switch is well suited to be integrated with transceivers for network protection. It uniquely integrated 8 2x2 bypass switches in a compact format that is activated by a single relay, offering high reliability and low cost.

The FF Series fiber optic switch connects optical channels by direct fiber-to-fiber connection via a proprietary MEMS platform using a ribbon fiber array and activated via an electromagnet relay. The advanced design significantly increases the performance, offering unprecedented low optical loss, little wavelength dependence with no coatings, high speed, vibration insensitivity, high reliability, as well as low cost. Latching operation preserves the selected optical path after the electrical power has been removed. The switch is bidirectional and conveniently controllable by 4.5V.

Using no lens, the FF Series switch can accommodate all types of fibers, including SM, MM, PM, double cladding, bendable, large core, small core. The FF switches provide performance for special fiber no other technology can match.

Lightpath in the device is bidirectional.

### Specifications

Parameter	Min	Typical	Max	Unit
Wavelength	350		2500	nm
Insertion Loss <sup>[1]</sup>	0.01	0.2	0.4	dB
Wavelength Dependent Loss			0.01	dB
Polarization Dependent Loss			0.05	dB
Return Loss	50 (SM)			dB
	35 (MM) <sup>[3]</sup>			dB
Cross Talk	50		75	dB
Optical Rise/Fall Time <sup>[2]</sup>	5		50	ms
Repetition Rate			1	Hz
Repeatability			± 0.02	dB
Durability	10 <sup>8</sup>			cycles
Operating Optical Power <sup>[3]</sup>		0.3	0.5	W
Operating Voltage	4.3		4.5	VDC
Operating Current		30	60	mA
Switching Type	Latching			
Operating Temperature	-40		80	°C
Storage Temperature	-50		90	°C

#### Notes:

[1]. Excluding Connectors. For fiber core >8 μm

[2]. Define as 10/90 % optical signal change. Slow MEMS chip can use all fiber types. Fast MEMS chip can only use SM fibers and PM1550. It can be used for other PM fiber but need NRE charge which is suitable for volume orders.

[3]. For 1310/1550nm. The optical power handling rapidly reduces as fiber core size/ reduces. At 650nm the max is 2mW. Expanding the fiber core can increase the power handling.

**Legal notices:** All product information is believed to be accurate and is subject to change without notice. Information contained herein shall legally bind Agiltron only if it is specifically incorporated into the terms and conditions of a sales agreement. Some specific combinations of options may not be available. The user assumes all risks and liability whatsoever in connection with the use of a product or its application.

Rev 01/18/24

# Fiber-Fiber™ Optical Switch

## Quad (4) 2x2 Bypass

(SM, MM, Broadband, Bidirectional)



### DATASHEET

#### Light Path Illustration

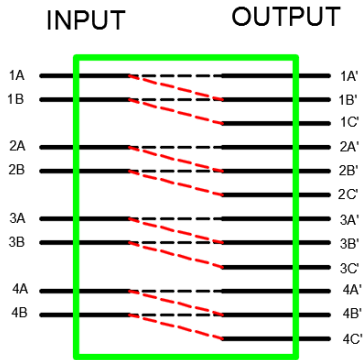

Quad 2x2 Bypass

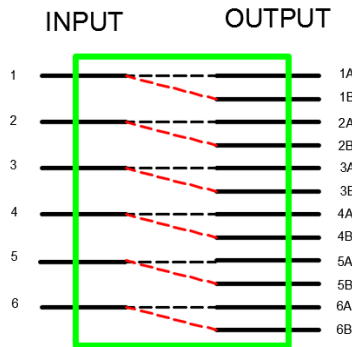

Hexa 1x2

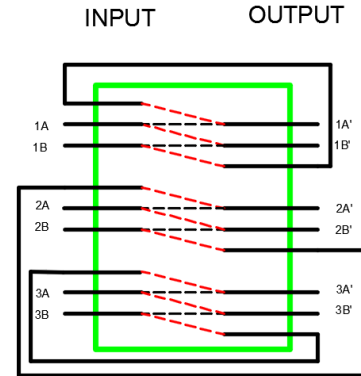

Triple 2x2 Full

#### Mechanical Dimensions (Unit: mm)

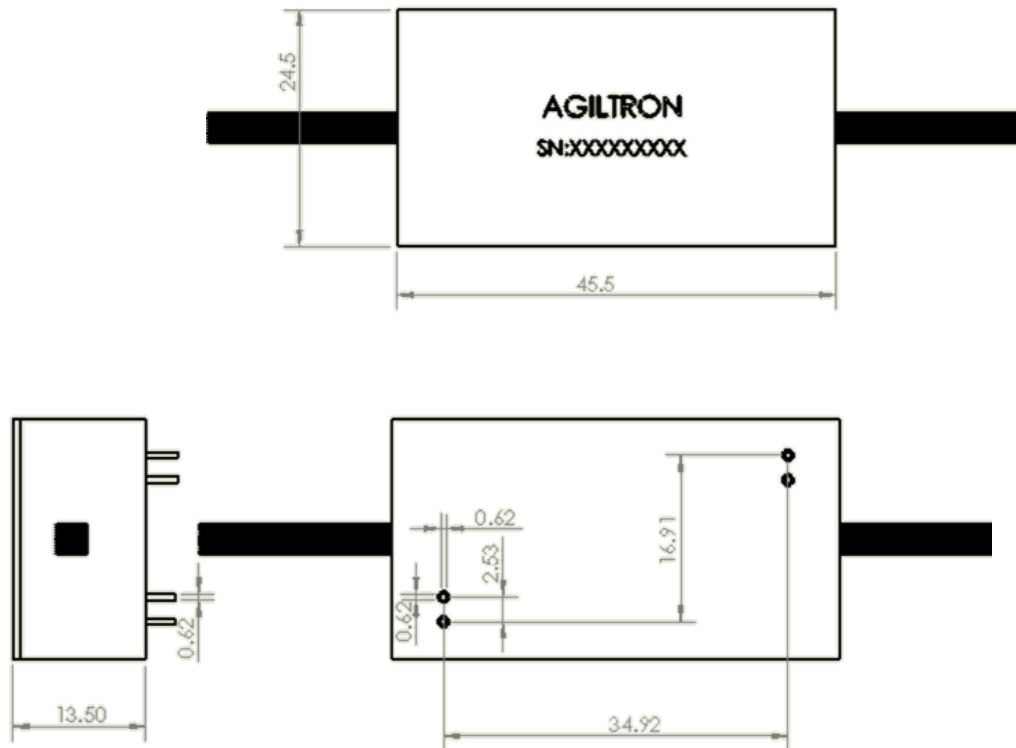

\*Product dimensions may change without notice. This is sometimes required for non-standard specifications.

# Fiber-Fiber™ Optical Switch Quad (4) 2x2 Bypass

(SM, MM, Broadband, Bidirectional)



## DATASHEET

### Typical Response Speed (SM Package F )



Channel 1 Optical Rise and Fall

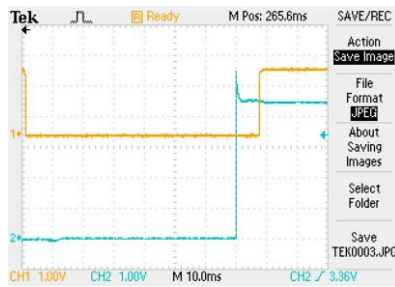

Channel 2 Optical Rise and Fall

### Electrical Connector Configurations

**Important Note:** The device must be driven by the reference circuit. Otherwise, it is not stable. This is because the device contains a permanent magnet inside; thus current must flow in the correct direction to counter the magnet field.

The load is a resistive coil which is activated by applying 4.5V (draw ~ 40mA). Agiltron offers a computer control kit with TTL and USB interfaces and Windows™ GUI. We also offer RS232 interface as an option – please contact Agiltron sales. The switch can withstand 5V which may reduce its durability.

#### Latching Type – Single Coil

**Application Note:** Applying a constant driving voltage increases stability. The switches can also be driven by a pulse mode using Agiltron recommended circuit for energy saving.

##### FF 1x2 Switch

Optical Path	Electric Drive	
	Pin 2	Pin 3
Port 1 → Port 2	4.5V	0V
Port 1 → Port 3	0V	4.5V

#### Non-Latching Type

##### FF 1x2 Switch

Optical Path	Electric Drive	
	Pin 2	Pin 3
Port 1 → Port 2	0V	0V
Port 1 → Port 3	0V	4.5V

# Fiber-Fiber™ Optical Switch Quad (4) 2x2 Bypass

(SM, MM, Broadband, Bidirectional)



## DATASHEET

### Ordering Information

Prefix	Type	Wavelength <sup>[3]</sup>	Fiber Type	Fiber Cover	Fiber Length	Connector
<b>FFSW-</b>	4 2x2 bypass = 042B 6 1x2 = 061S 8 2x2 bypass = 082B 3 2x2 full = 032F 12 1x2 = 121S	850 = 8 1310 = 3 1550 = 5 Special = 0	50/125 = 1 62.5/125 = 2 SM28 = 3 Special = 0	Tight buffer = 1 900um tube = 3 Special = 0	0.25m = 1 0.5m = 2 1.0m = 3 Special = 0	None = 1 FC/PC = 2 FC/APC = 3 SC/PC = 4 SC/APC = 5 ST/PC = 6 LC/PC = 7 Duplex LC/PC = 8 MTP = 9 LC/APC = A LC/UPC = U Special = 0

#### Fiber Core Alignment

Note that the minimum attenuation for these devices depends on excellent core-to-core alignment when the connectors are mated. This is crucial for shorter wavelengths with smaller fiber core diameters that can increase the loss of many decibels above the specification if they are not perfectly aligned. Different vendors' connectors may not mate well with each other, especially for angled APC.

#### Fiber Cleanliness

Fibers with smaller core diameters (<5 μm) must be kept extremely clean, contamination at fiber-fiber interfaces, combined with the high optical power density, can lead to significant optical damage. This type of damage usually requires re-polishing or replacement of the connector.

#### Maximum Optical Input Power

Due to their small fiber core diameters for short wavelength and high photon energies, the damage thresholds for device is substantially reduced than the common 1550nm fiber. To avoid damage to the exposed fiber end faces and internal components, the optical input power should never exceed 20 mW for wavelengths shorter 650nm. We produce a special version to increase the how handling by expanding the core side at the fiber ends.

# Fiber-Fiber™ Optical Switch Quad (4) 2x2 Bypass

(SM, MM, Broadband, Bidirectional)



## DATASHEET

### Driver Reference Design

